

01 April 2023 Lucy Clark Spring Dance

ECCLEFECHAN FELINE				8x32 J
<p style="text-align: center;">take hands</p>			<p style="text-align: center;">RA</p>	<p style="text-align: center;">LA</p>

Bob McMurtry, Le Petit Chat Celtique

3C/4C longwise set.

THE OLD MAN OF STORR				8x32 R	
<p>1 2</p> <p>RA</p>		<p>1x 3</p> <p>LA</p>		<p>S</p>	<p>2 1</p> <p>RL</p>

Roy Goldring, 1980, RSCDS Childrens Book .6

3C/4C longwise set.

THE SILVER TASSIE				8x32 S
<p>1 2 3</p> <p>X_R S X_R S</p>	<p>◇ 2 ◇ 3</p> <p>DOUBLE FIGURE EIGHT</p>			<p>1 2</p> <p>Rondel</p>

John Drewry, 1966, RSCDS Leaflet 1

3C/4C longwise set.

FAREWELL TO BALFOUR ROAD				96 J	
5 couples, 2C start on bar 17					
<p>1 2</p>	<p>1 2</p> <p>S & LINK</p>	<p>1 3</p> <p>S & LINK</p>	<p>1 4 5</p>	<p>S</p> <p style="text-align: center;">R</p>	<p>1x</p> <p>S</p> <p style="text-align: center;">L</p>

Andrew Buxton, 2015, RSCDS Book 52.7

5C/5C longwise set.

GENERAL STUART'S REEL				The New Way of Gildon	8x32 R
<p>S</p>	<p>S</p>	<p>T_R</p> <p style="text-align: center;">T_L</p>	<p>S S S S</p>	<p>X_R</p>	

Castle Menzies, 1749, RSCDS Book 10.3

3C/4C longwise set.

MacDONALD OF KEPPOCH		2x32 S + 2x32 R	
<p>1 3</p> <p>RL₃ 4</p> <p style="text-align: right;">S</p>		<p>2 2</p> <p>4 4</p>	
<p style="text-align: center;">S</p>	<p style="text-align: center;">ALL</p> <p style="text-align: center;">T_{R1}¹/₄</p> <p style="text-align: center;">4 bars</p>	<p style="text-align: center;">ALL</p> <p style="text-align: center;">PROM</p> <p style="text-align: center;">1 place Anticlockwise to 2 3 4 1</p>	

Chris Ronald, 2013, RSCDS Book 49.11

4C/4C square set.

THE LAIRD OF MILTON'S DAUGHTER				8x32 J				
<p>S</p>	<p>X_R</p>	<p>1</p> <p>T_L</p>	<p>Corner chain</p> <p>T_R₂¹</p>	<p>T_L</p>	<p>T_R₂¹</p>	<p>T_L₄¹</p>	<p>R</p>	<p>2 1 3</p> <p style="text-align: center;">6</p>

Lord Craigmyle, RSCDS Book 22.10

3C/4C longwise set.

THE PAISLEY WEAVERS		3 Cpl set. 2C start on opp side		3x32 S	
	<p>1 2 3</p> <p>CHAIN</p> <p>1 2 3</p>	<p>1 2x</p>	<p>1 2x</p> <p>RL</p>	<p>1x 3</p> <p>RL</p> <p>to 2 3x 1</p>	

Derek Haynes, Carnforth Collection 6, RSCDS Graded Book 3.5

3C/3C longwise set.

J. B. MILNE				8x32 R							
<p>S₁</p>	<p>T_R</p>	<p>S₂</p>	<p>T_R</p>	<p>S₃</p>	<p>T_B</p>	<p>T_◇</p>	<p>X_R</p>	<p>S</p>	<p>T_R₄³</p>	<p>X_R</p>	<p>S</p>
<p>3 1 2</p> <p>X_R</p>	<p>S</p>	<p>T_R₄³</p>	<p>X_R</p>	<p>3 2</p> <p>X_R</p>	<p>S</p>	<p>1 1</p> <p>S</p>	<p>X_R</p>	<p>2 1 3</p> <p>S</p>	<p>2 3</p> <p>X_R</p>	<p>S</p>	<p>1 2 3</p> <p>S</p>

Hugh Foss, 1954, Angus Fitchet S D Album, RSCDS Thirty Popular Dances Vol 2

3C/4C longwise set.

THE SUMMER ASSEMBLY				88 R				
ALL T_R			R	ALL T_L		ALL S	R	
3 1 RA		2 4 R	Women 	Men 	1 3 S	1 3 S	2 4 R	8

Roy Goldring, 1985, RSCDS Book 35.8

4C/4C square set.

THE GENTLEMAN				8x32 S			
T_B			S		T_L^{1/2}		S
	T_L^{1/2}		S		P	2 1	P

Roz Scott Huxley, 1986, RSCDS Book 35.5, RSCDS Thirty Popular Dances Vol 2

3C/4C longwise set.

MISS HADDEN'S REEL				8x32 J	
6	S	2 1 3 T_R	2 1 3 A	3 1 2 ↑	





RSCDS Publications Committee, 1967, RSCDS Book 23.5

3C/4C longwise set.

ANDREW'S DANCE				8x32 R	
		2 1x 	T_R		S

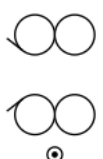
Andrew Mills, Harbour City (NZ)

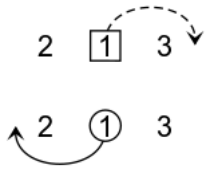
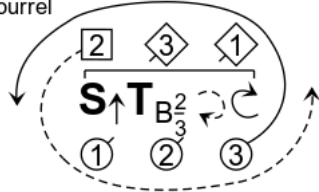
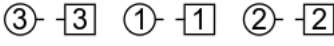
3C/4C longwise set.

MISS ELEANOR		3x32 S
	S 	T_R 
Bourrel 	 S T_B³₄	3 1 2 

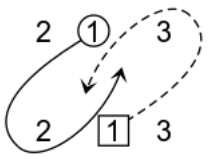
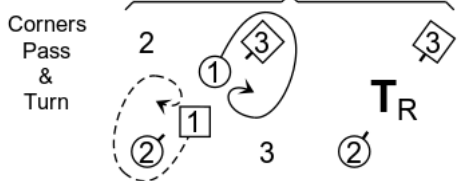
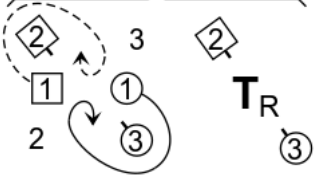
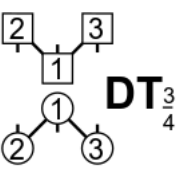
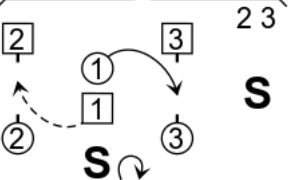
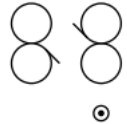

Ann Dix, 2013, RSCDS Book 49.5

3C/3C longwise set.

THE CHEQUERED COURT		8x32 J
X_R 		Corners Pass & Turn  T_R
 T_R	 DT₃₄	 S
		 X_R

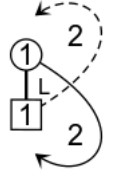
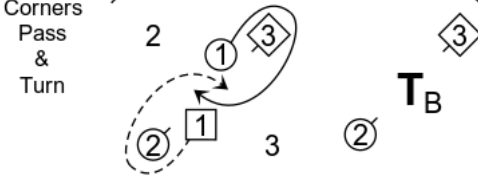
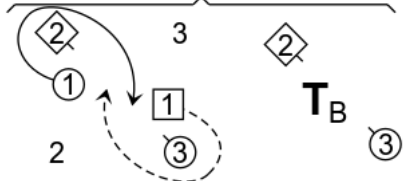

Duncan Brown, 2001, RSCDS Book 42.3

3C/4C longwise set.

TRIPLE HAPPINESS		3x32 S
take R hands briefly T_L¹₂		1 2 KNOT
		Corners Pass & Turn  T_B
 T_B	2 1 3 	3x 1x 2x T_B¹₂

Yoshiki Oyama, 2016, RSCDS Book 52.10

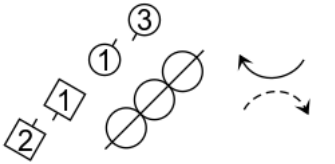
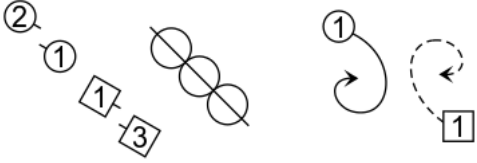
3C/3C longwise set.

GLASTONBURY TOR			8x32 R
<p style="text-align: center;">1 2</p> <p style="text-align: center;">S RA</p>	<p style="text-align: center;">1x 3</p> <p style="text-align: center;">S LA</p>	<p style="text-align: center;">S X_R ↺¹ T_L</p>	
		<p style="text-align: center;"> 3 S 2 1 & 1 3 LINK 2 </p>	<p style="text-align: center;"> 3 1 2 3x 2x T_R1¹/₂ 3 1 2 </p> 

Duncan Brown, 2001, RSCDS Book 47.11

3C/4C longwise set.

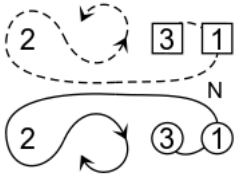
THE REEL OF THE ROYAL SCOTS			8x32 R
<p style="text-align: center;"> 1—2 T_L¹/₂ 1—2 T_R¹/₂ </p>	<p style="text-align: center;"> 2—1—3 S 2—1—3 </p>	<p style="text-align: center;"> 1—3 T_R¹/₂ 1—3 T_L¹/₂ </p>	<p style="text-align: center;"> 2—3—1 S 2—3—1 </p>
	<p style="text-align: center;">T_R ↺</p> <p style="text-align: center;">Corners: 4 bar turns</p>	<p style="text-align: center;">T_R ↺</p>	<p style="text-align: center;">2 1 3</p> <p style="text-align: center;"> 6 </p>

Roy Goldring, 1983, RSCDS Leaflet 7

3C/4C longwise set.