

Social 25 May 2023 Lucy Clark

THE HAAR ON SKYE		8x32 S	
1 2 ④		1 2 RONDEL	2 1 3 CHAIN

Marilyn Watson, 1997, Stepping Out 3, RSCDS Graded Book 3.7

3C/4C longwise set.

EH3 7AF		8x32 J	
	1 2 3 PROM ①		

Roy Goldring, 1998, RSCDS Book 40.6

3C/4C longwise set.

THE HAPPY WEASEL		8x32 J	
S ①	2 1 3 S T S X_R S T	Weasel Reel 1/2 reel of 4 & 1/2 chase All dance clockwise back to starting positions	
2 1x 3 S T S₂ S T			3 1 2 A

Livia Kohn, Suncoast Collection

3C/4C longwise set.

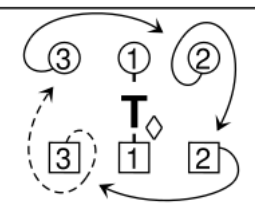
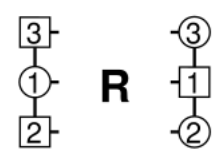
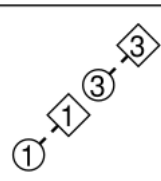
ORWELL LODGE STRATHSPEY		3x32 S	
1 2 KNOT $T_{L\frac{1}{2}}$		3x 1x 2x S	
	2 1 3 S T_B		1 3 P

Ian Brockbank, 2005, RSCDS QE Diamond Jubilee

3C/3C longwise set.

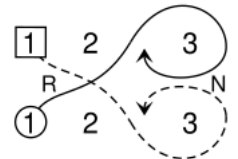
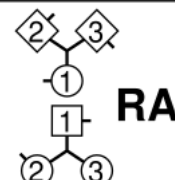
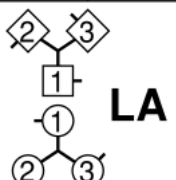
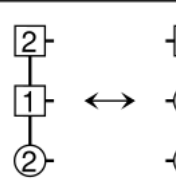
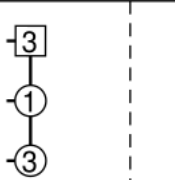
THE NURSERYMAN		8x32 J	
S		ALL S	ALL S
	RA		LA
	$T_{R1\frac{1}{4}}$		

Steven Brown, 1988, RSCDS Book 37.7

3C/4C longwise set.

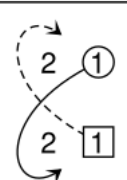
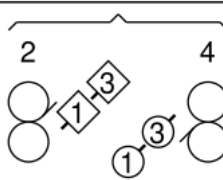
SCOTT MEIKLE		4x32 R	
X_R 1		1 3 RA LA	2 3 $\overline{1}$ $\overline{4}$ RL
		2 3 $\overline{1}$ $\overline{4}$ RL	4x 1x $T_{R1\frac{1}{2}}$

Alice McLean, Laurieston Collection 1, RSCDS Book 46.3

4C/4C longwise set.