

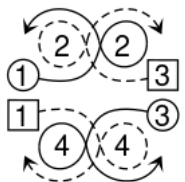

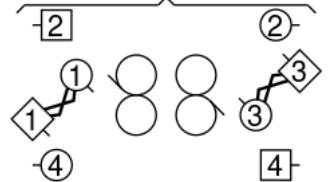

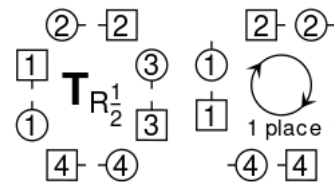
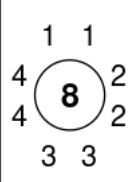
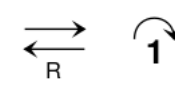

# Social 27 April 2023 Lucy Clark

<b>FLIGHT TO MELBOURNE</b>			<b>4x32 R</b>	
		ALL <b>S</b> & LINK		



Shirley Campbell, Leicester Silver Collection, RSCDS Book 47.3

4C/4C square set

<b>CABBAGES AND KINGS</b>				<b>8x32 J</b>	
1 2  <b>RL</b>		2  3  <b>T<sub>R</sub></b> ② ① 3	  3  <b>T<sub>L</sub></b> 2 ① ③	2  ① 3  <b>RA</b>	2 ①  3  <b>LA</b>

Romaine Butterfield, The Harbour City

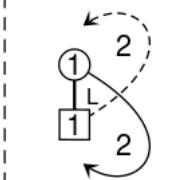
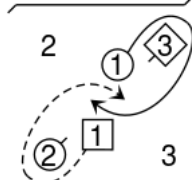
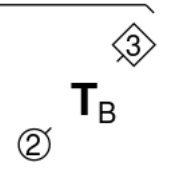
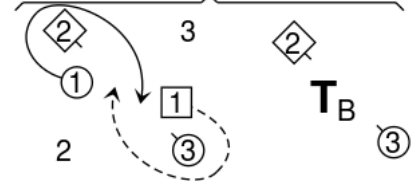
3C/4C longwise set

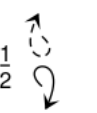
<b>TRIPLE HAPPINESS</b>			<b>3x32 S</b>	
		1 2  <b>KNOT</b>	Corners Pass & Turn 	
		2 1 3  	3x 1x 2x  <b>T<sub>B</sub><sup>1/2</sup></b> 	

Yoshiki Oyama, 2016, RSCDS Book 52.10

3C/3C longwise set

<b>THE FIREWORKS REEL</b>		<b>8x32 R</b>		
<b>X<sub>R</sub></b> 1 ↻		<b>S</b> ↻	2 ① 3 <b>T<sub>L</sub></b> <sup>3</sup> <sub>4</sub> 2 ① 3	
<b>S</b> ↻	2 2 ① <b>T<sub>L</sub></b> <sup>3</sup> <sub>4</sub> ① 3 3		3x 1x 2x 	

Anselm Lingnau, 2009, my.strathspey.org/u/anselm/dances/, RSCDS Book 48.11

3C/4C longwise set

<b>STAIRCASE IN STYRIA</b>		<b>5x40 R</b>	
 <b>RA</b> <sub>1 1/4</sub>	 <b>LA</b>	 <b>RA</b>	 <b>LA</b> <sub>1 1/4</sub>
	<b>X<sub>R</sub></b> 1 ↻		1x <b>X<sub>R</sub></b> 1 ↻

Margaret Gray, CD booklet of The Sunday Class Book 2

5C/5C longwise set

<b>SHIFTIN' BOBBINS</b>		<b>8x32 R</b>	
 <b>S</b>		 <b>LA</b>	 <b>RA</b>
 <b>RA</b>	 <b>LA</b>		

Roy Clowes, Ormskirk Book 6, RSCDS Thirty Popular Dances Vol 2

3C/4C longwise set