

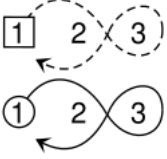

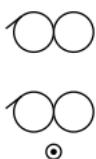
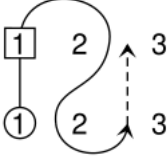
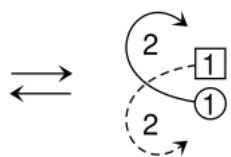

# Social diagrams 23 November 2023 Lucy Clark

<b>NEW YEAR JIG</b>			<b>8x32 J</b>	
			1 3 <b>RA</b>	2 1 <b>LA</b>

Maureen Robson, 1995, RSCDS Book 51

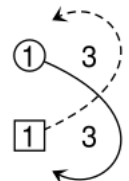
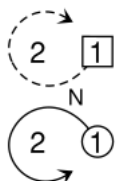
3C/4C longwise set.

<b>THE BUNTING BEE</b>				<b>8x32 S</b>	
	 <p style="text-align: center;"><b>CHAIN</b></p>			2 1 3 	

Rod Downey, 2014, The Johnsonville Collection

3C/4C longwise set.

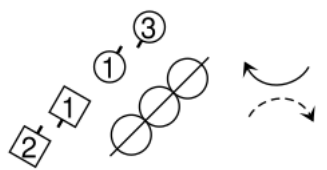
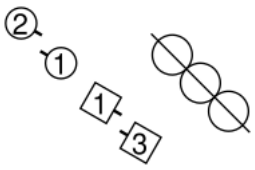
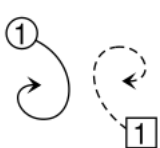
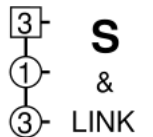
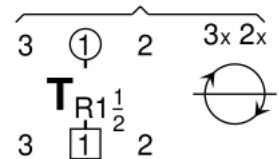
<b>GLASTONBURY TOR</b>			<b>8x32 R</b>		
1 2 <b>S RA</b>	1x 3 <b>S LA</b>	<b>S X<sub>R</sub></b> ↻ <b>1</b> <b>T<sub>L</sub></b>			
			 <p style="text-align: center;"><b>S</b> &amp; <b>LINK</b></p>	 <p style="text-align: center;"><b>T<sub>R</sub>1<sup>1</sup>/<sub>2</sub></b> 3x 2x</p>	





Duncan Brown, 2001, RSCDS Book 47.11

3C/4C longwise set.

<b>THE COLLEGE HORNPIPE</b>			<b>8x32 R</b>	
1 2 3 	1 2 3 <b>PROM</b>	<b>X<sub>R</sub></b> ↻ <b>1</b> <b>X<sub>L</sub></b> ↻ <b>1</b> ↻ <b>1</b>	<b>S</b> <b>S</b> <b>S</b> <b>T<sub>◇</sub></b> ✖	

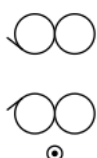
Boag, 1797, RSCDS Book 20.12

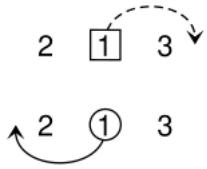
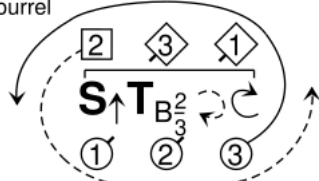
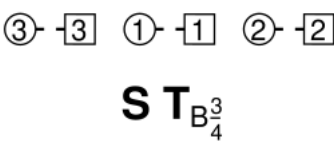
3C/4C longwise set.

<b>MISS ELEANOR</b>		<b>3x32 S</b>
	<b>S</b> 	<b>T<sub>R</sub></b> 
Bourrel 	 <b>S T<sub>B<sup>3</sup>/<sub>4</sub></sub></b>	3 1 2 

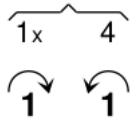
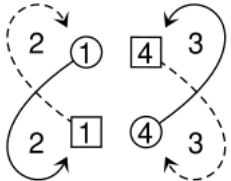
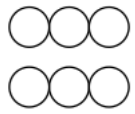
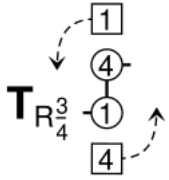
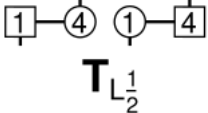
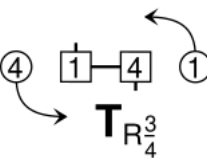
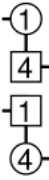

Ann Dix, 2013, RSCDS Book 49.5

3C/3C longwise set.

<b>JAMES GRAY</b>		3C & 4C cross on 2nd chord	<b>4x32 J</b>
1 4x <b>X<sub>R</sub></b> 		1 4x <b>RL</b>	2 1 4x 3x 
			 <b>T<sub>L<sup>3</sup>/<sub>4</sub></sub></b> to 2 4 1x 3x

Ronella Burrows, RSCDS Book 42.10

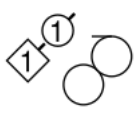
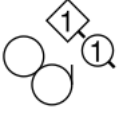
4C/4C longwise set.

<b>THE FLIGHT OF THE FALCON</b>		<b>8x32 J</b>	
<b>S</b>  <b>T<sub>L<sup>1</sup>/<sub>4</sub></sub></b>	 Change lead at ends of reel	 Change lead at ends of reel	<b>T<sub>R</sub></b>  <b>T<sub>R</sub></b> 

Barry Priddey, Anniversary Tensome

3C/4C longwise set.