

# Social diagrams 19 October 2023 Lucy Clark

<b>THE BARMKIN</b>						<b>88 R</b>		
1 3 <b>T<sub>R</sub></b>		3 1 <b>RA LA</b>	2 4 <b>R</b> 16 bars	3 1 <b>T<sub>L</sub></b>		1 3 <b>RL</b>	4 2 <b>R</b> 16 bars	
								8

Roy Goldring, 24 Graded & Social Dances, RSCDS Graded Book 2.6

4C/4C square set.

<b>RAKES OF GLASGOW</b>				<b>8x32 S</b>	
1 2 <b>RL</b>		1 2 <b>A</b>	2 1 3 6		



Preston, 1806, RSCDS Book 11.11

3C/4C longwise set.

<b>LADY DUMFRIES</b>						<b>8x32 R</b>	
1 2 <b>RL</b>	2 1 →	2 1 ←	2 1 3 <b>S X<sub>R</sub></b>	2x 1x 3x <b>S</b>		2 1 3 <b>X<sub>R</sub></b>	2 1 3 <b>DT</b>

RSCDS MMM (44)

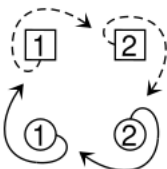
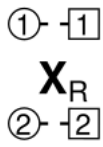
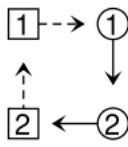
3C/4C longwise set.

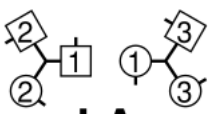
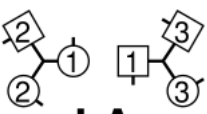
<b>A CAPITAL JIG</b>		<b>8x32 J</b>	
Set and Rotate 1 2 <b>S</b> 	 <b>X<sub>R</sub></b>		
<b>S T<sub>R</sub><sup>3</sup><sub>4</sub></b>	 <b>LA</b>	2 ① 3 <b>S T<sub>R</sub><sup>3</sup><sub>4</sub></b> 2 ① 3	 <b>LA</b>

Tine Mackay, RSCDS 5/2009

3C/4C longwise set.

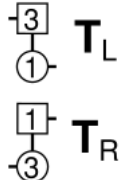
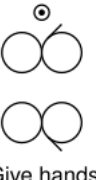
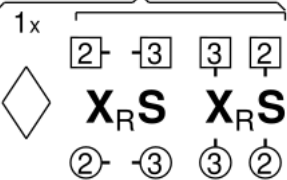
<b>KILKENNY CASTLE</b>			<b>8x32 S</b>	
1 2 <b>S X<sub>R</sub></b> ①	 <b>T<sub>L</sub></b> <b>T<sub>R</sub></b>	 Give hands	1x  <b>X<sub>R</sub> S X<sub>R</sub> S</b> ② - ③ ③ ②	3 ① ② ③ ① 3 ③ ① 2 2 ① ② <b>RL</b> <b>RL</b>

Bill Forbes, Craigievar Book 2

3C/4C longwise set.

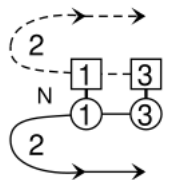
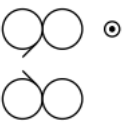
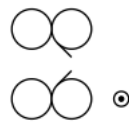
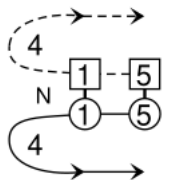
<b>MISS JOHNSTONE OF ARDROSSAN</b>				<b>5x32 R</b>	
<b>S</b> ①	 N	1 4 5 	2 3 1x 	<b>S</b> ①	 N

Roy Goldring, 2000, 14 Social Dances for 2000, RSCDS Thirty Popular Dances Vol 2

5C/5C longwise set.

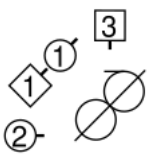
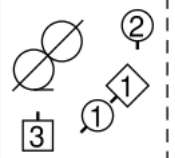
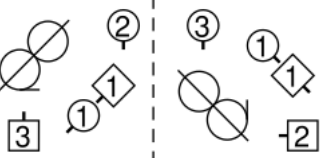
<b>PELORUS JACK</b>				<b>8x32 J</b>	
1x 3 <b>X<sub>R</sub></b> ① <b>RA</b>	 Change lead at end of reel	 Change lead at end of reel		2 1x 1x 2 1 3 <b>LA T<sub>L</sub><sup>1</sup><sub>2</sub> S</b>	

Barry Skelton, 1993, Dolphin Book, RSCDS Book 41.1, RSCDS Thirty Popular Dances Vol 2

3C/4C longwise set.